



Faculty of Engineering

MEP 382: Design of Applied Measurement Systems

**Lecture 6:
Operational Amplifiers**

What is an Op-Amp? – The Surface

- An Operational Amplifier (Op-Amp) is an integrated circuit that uses external voltage to amplify the input through a very high gain.
- We recognize an Op-Amp as a mass-produced component found in countless electronics.



What an Op-Amp looks like to a lay-person

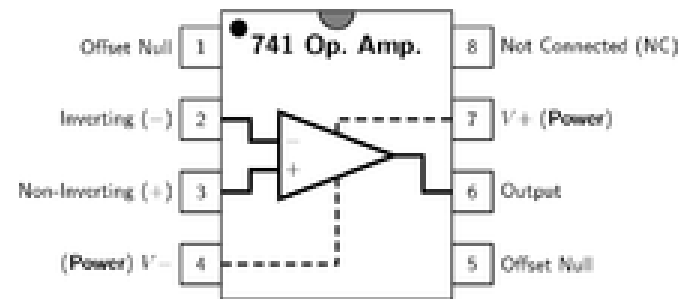

What an Op-Amp looks like to an engineer

What is an Op-Amp? – The Layout

- There are 8 pins in a common Op-Amp, like the 741 which is used in many instructional courses.

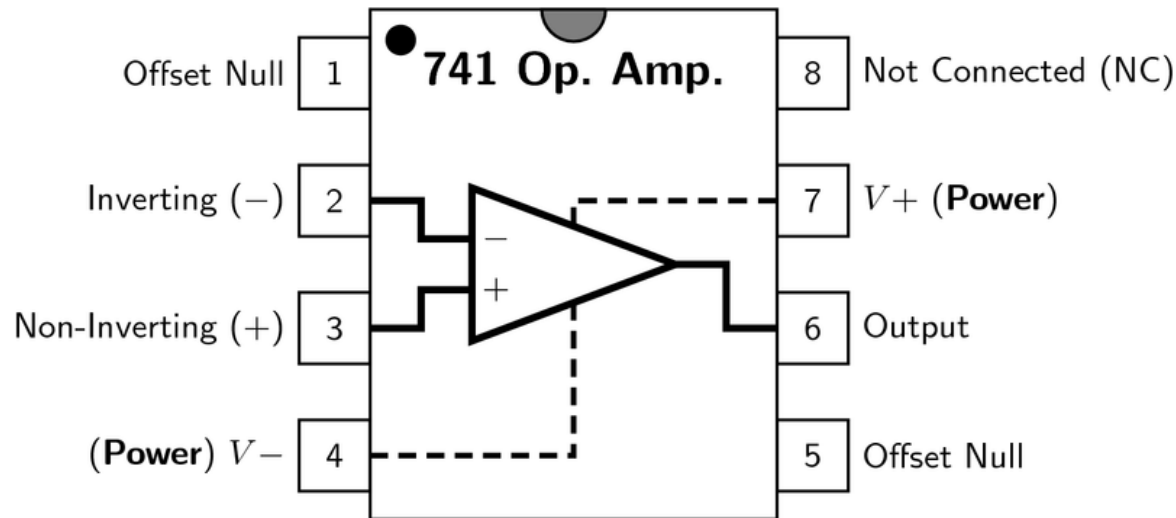

What is an Op-Amp? – The Inside

- The actual count varies, but an Op-Amp contains several Transistors, Resistors, and a few Capacitors and Diodes.
- For simplicity, an Op-Amp is often depicted as this:

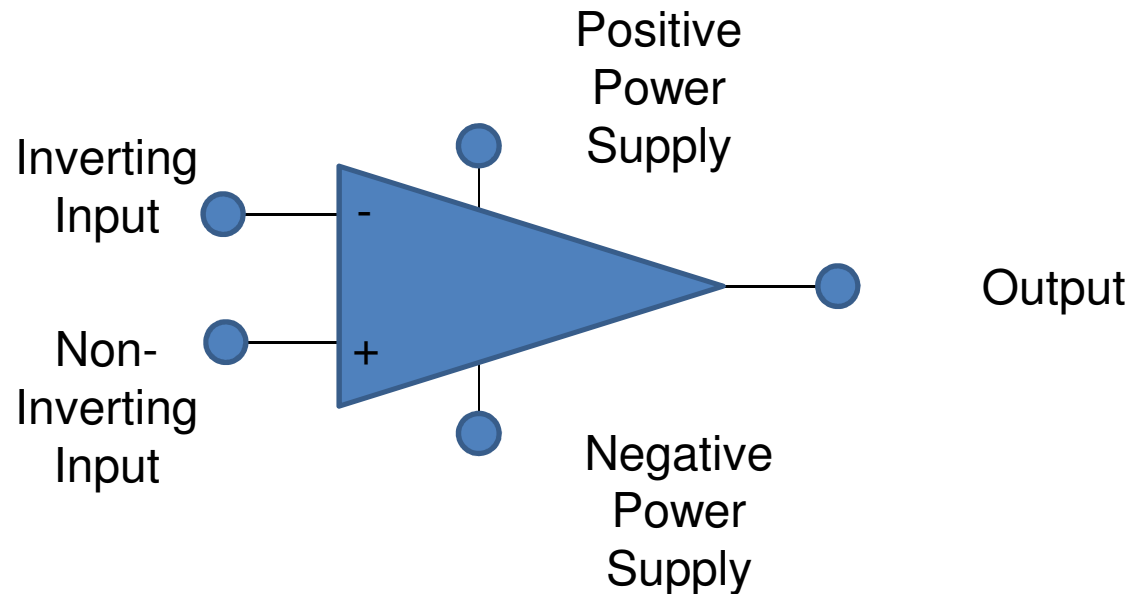

History of the Op-Amp – The Dawn

- Before the Op-Amp: Harold S. Black develops the feedback amplifier for the Western Electric Company (1920-1930)

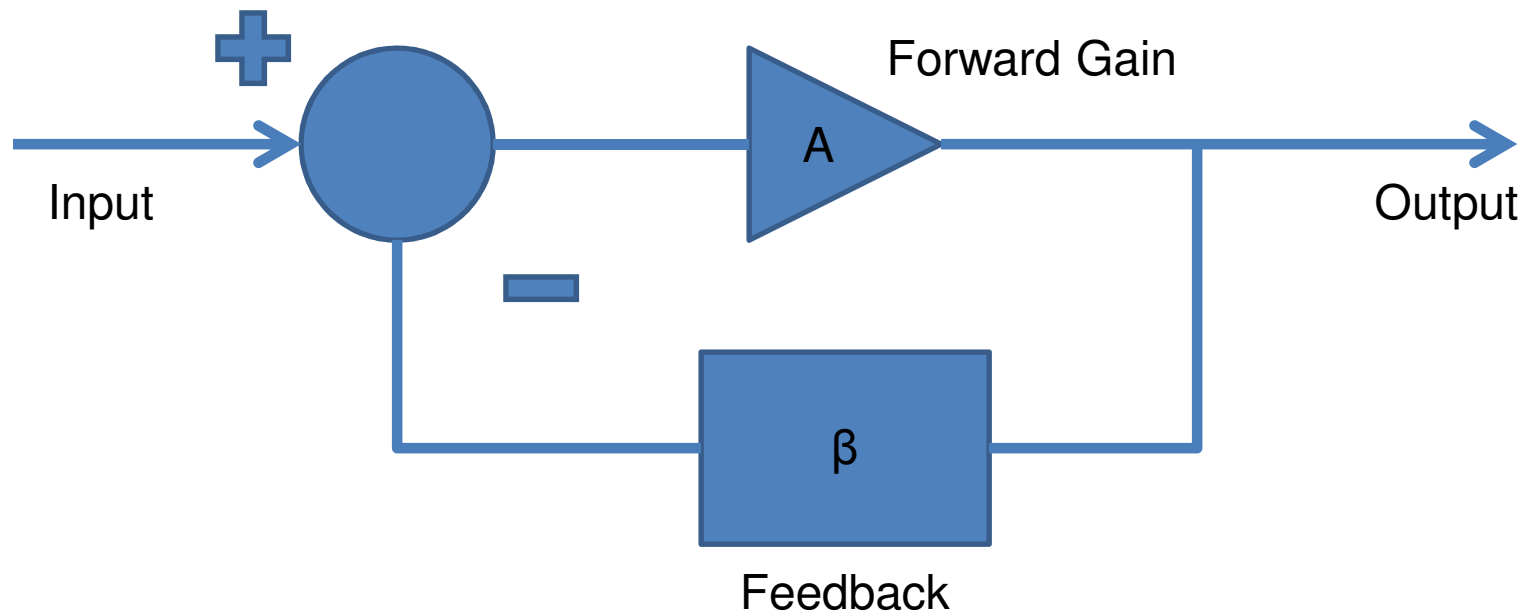

History of the Op-Amp – The Dawn

- **The Vacuum Tube Age**

- The First Op-Amp: (1930 – 1940) Designed by Karl Swartzel for the Bell Labs M9 gun director
- Uses 3 vacuum tubes, only one input, and ± 350 V to attain a gain of 90 dB
- Loebe Julie then develops an Op-Amp with two inputs: Inverting and Non-inverting

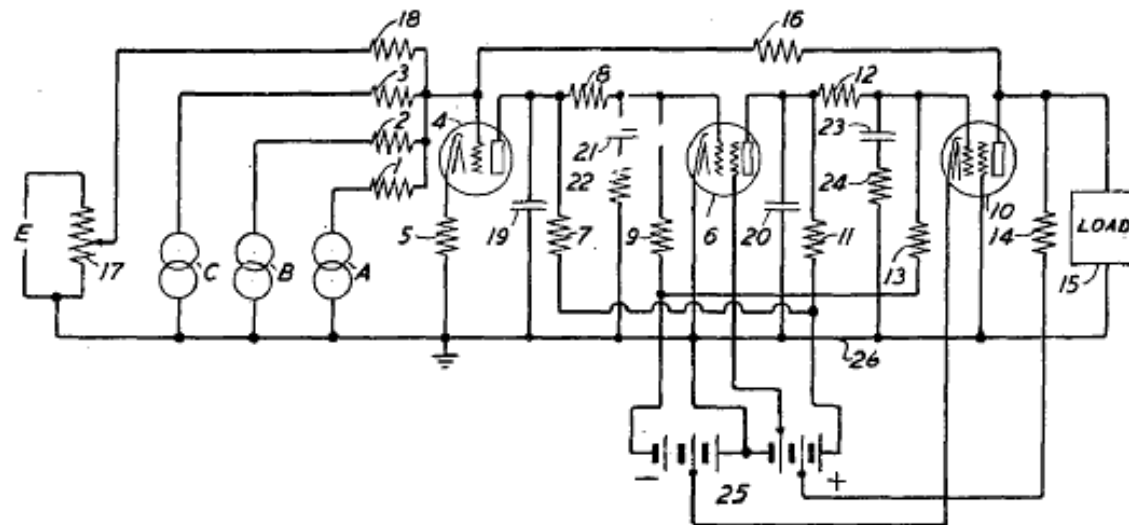

History of the Op-Amp – The Shift

- The end of Vacuum Tubes was built up during the 1950's-1960's to the advent of solid-state electronics

1. The Transistor
2. The Integrated Circuit
3. The Planar Process

History of the Op-Amp – The Shift

- 1960s: beginning of the Solid State Op-Amp
- Example: GAP/R P45 (1961 – 1971)
 - Runs on ± 15 V, but costs \$118 for 1 – 4
- The GAP/R PP65 (1962) makes the Op-Amp into a circuit component as a potted module

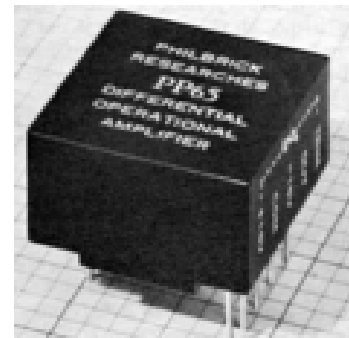
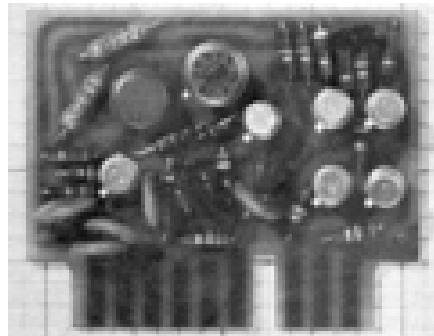

History of the Op-Amp – The Evolution

- The solid-state decade saw a proliferation of Op-Amps
 - Model 121, High Speed FET family, etc.
- Robert J. Widlar develops the μ A702 Monolithic IC Op-Amp (1963) and shortly after the μ A709
- Fairchild Semiconductor vs. National Semiconductor
 - National: The LM101 (1967) and then the LM101A (1968) (both by Widlar)
 - Fairchild: The “famous” μ A741 (by Dave Fullager 1968) and then the μ A748 (1969)

Mathematics of the Op-Amp

- The gain of the Op-Amp itself is calculated as:

$$G = V_{\text{out}} / (V_{+} - V_{-})$$

- The maximum output is the power supply voltage
- When used in a circuit, the gain of the circuit (as opposed to the op-amp component) is:

$$A_v = V_{\text{out}} / V_{\text{in}}$$

Op-Amp Saturation

- As mentioned earlier, the maximum output value is the **supply voltage**, positive and negative.
- The gain (G) is the slope between saturation points.

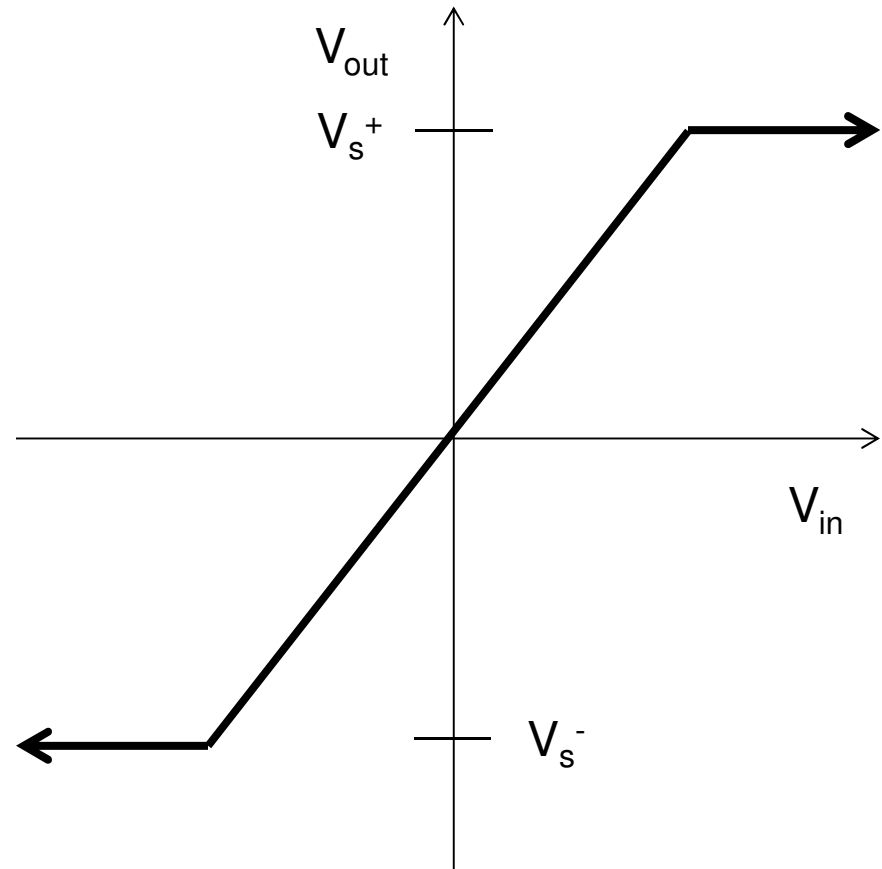

741 Op-Amp Schematic

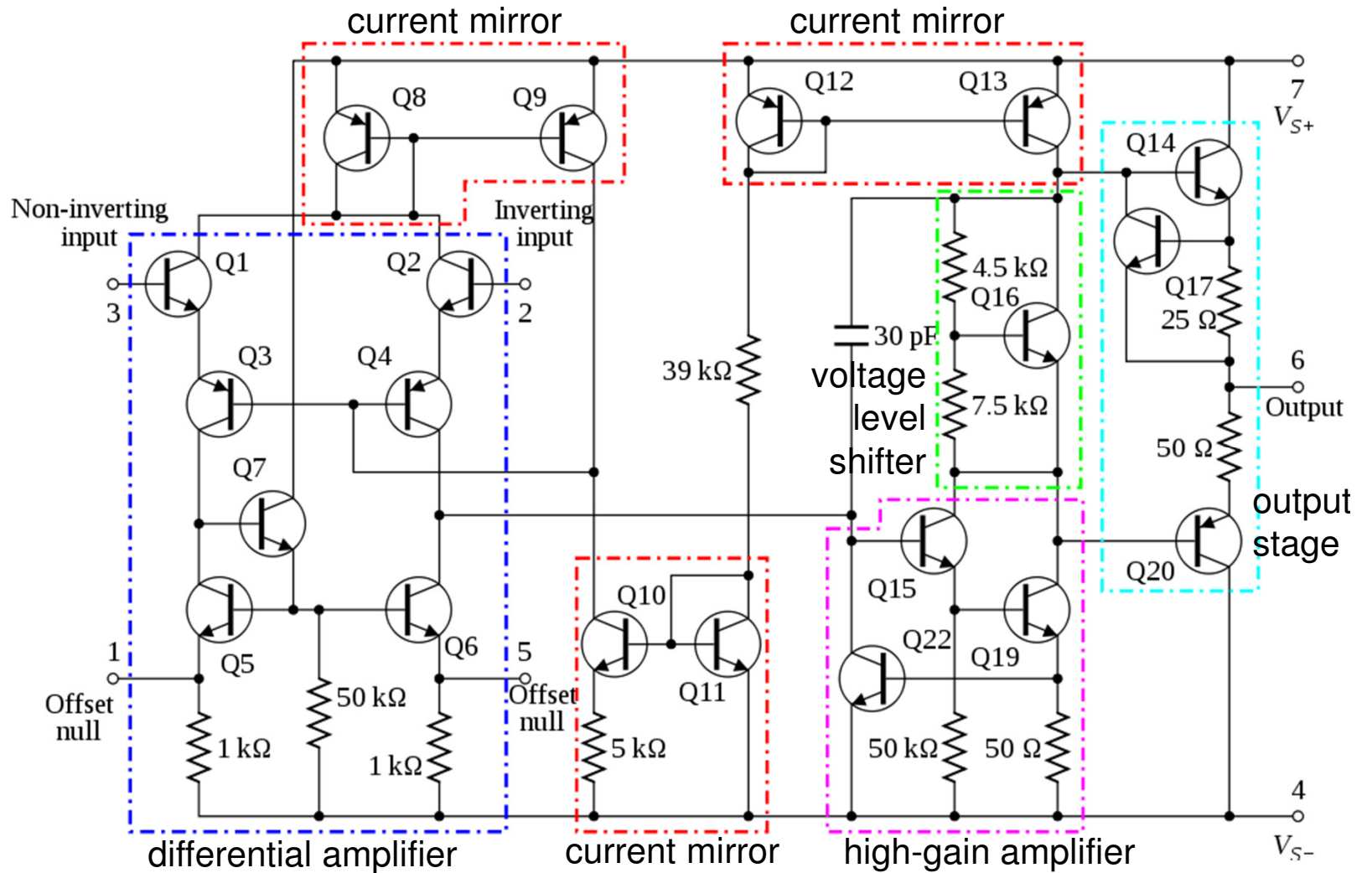

Op-Amp Characteristics

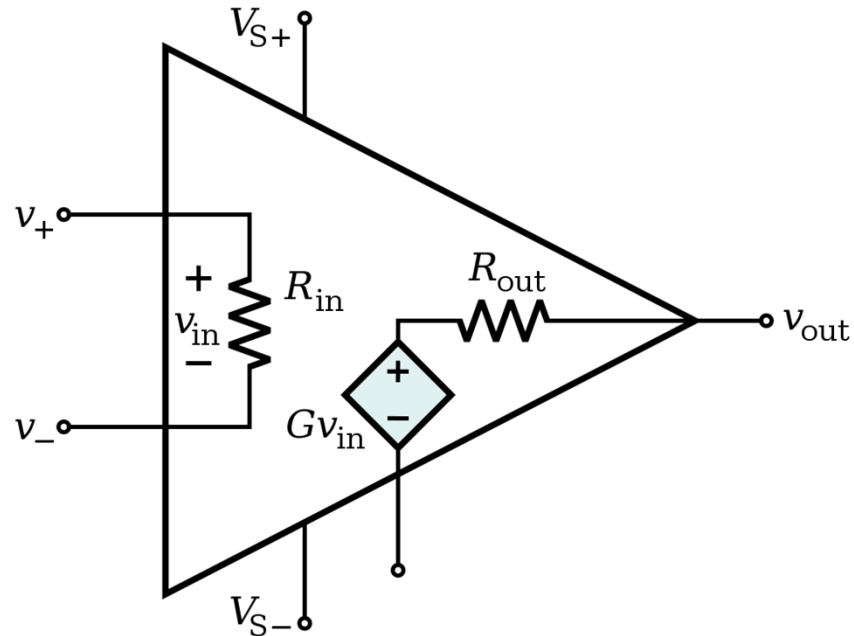

- Open-loop gain G is typically over 9000
 - But closed-loop gain is much smaller
- R_{in} is very large ($M\Omega$ or larger)
- R_{out} is small (75Ω or smaller)
 - Effective output impedance in closed loop is very small

Ideal Op-Amp Characteristics

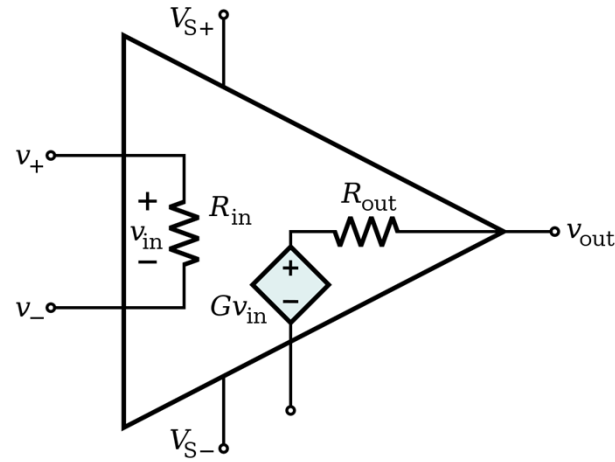

- Open-loop gain G is infinite
- R_{in} is infinite
 - Zero input current
- R_{out} is zero

Ideal Op-Amp Analysis

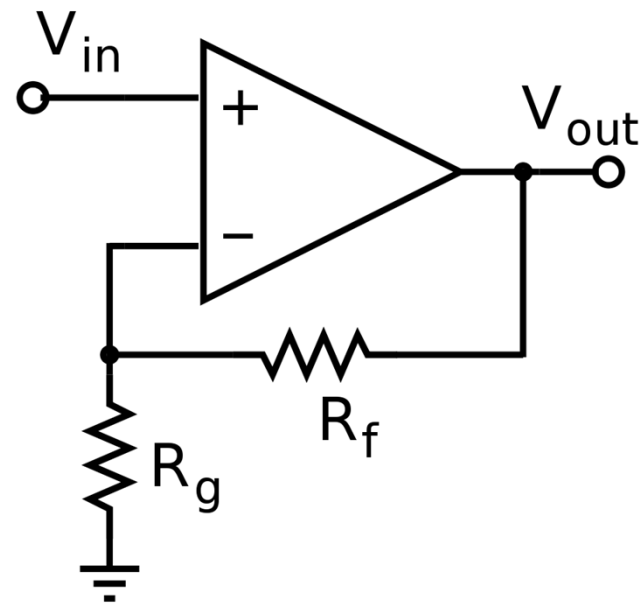

To analyze an op-amp feedback circuit:

- Assume no current flows into either input terminal
- Assume no current flows out of the output terminal
- Constrain: $V_+ = V_-$

Inverting Amplifier Analysis

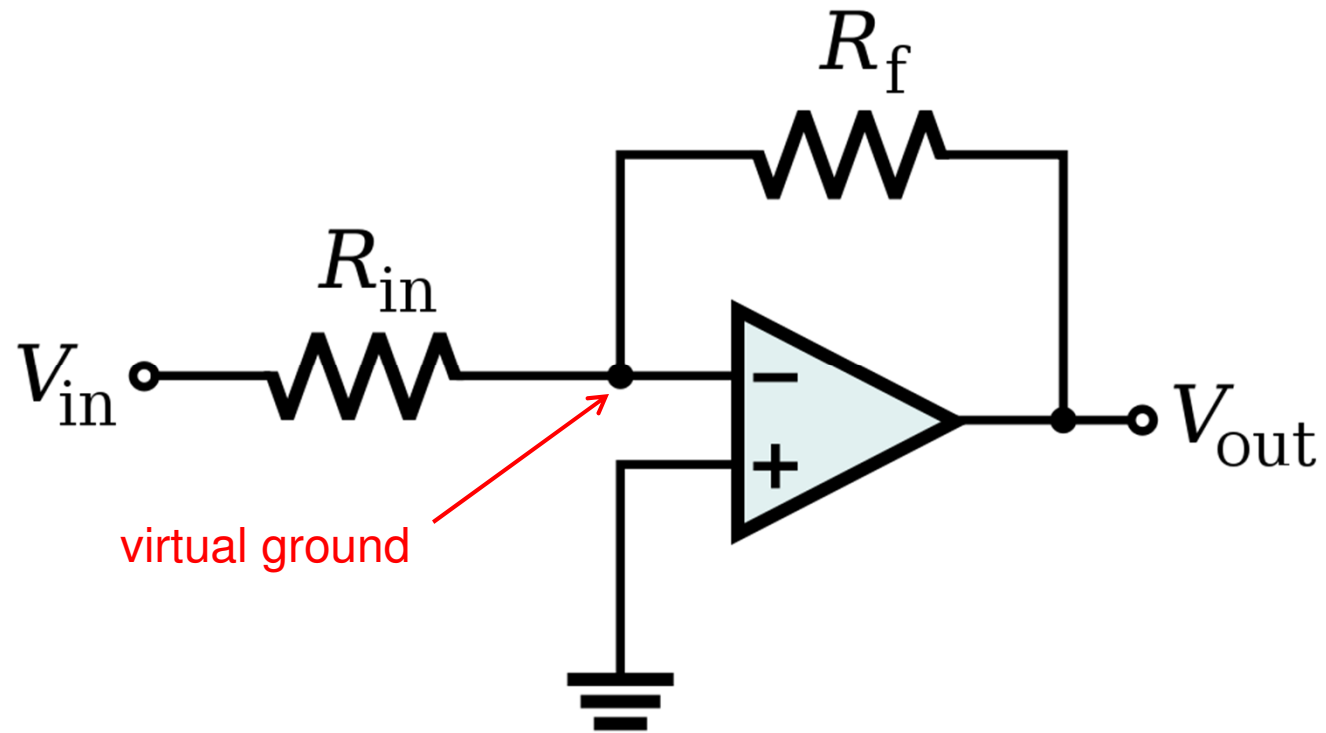

$$V_{out} = -\frac{R_f}{R_{in}} V_{in}$$