



## **MCT242: Electronic Instrumentation**

# **Lecture 11: Sensors**

Slides are borrowed from Dr. Moahmed Elshiekh lectures

# Outline

- What is a measurement system?
- Sensors and sensor types
- Characteristics of sensor
  - Static characteristics of sensors
  - Dynamic characteristics of sensors

# Types of sensors

- Sensors are considered as transducers that convert input energy of one form into output energy of another form.
- In many cases, it converts the input energy from many forms into output energy in a form of electrical energy to be signal processed.
- Sensors could be mainly **active/passive** and **analog/digital**.

# Types of sensors: Passive

- Do not add energy as part of the measurement process.
- The output power is almost entirely provided by the measured signal without an external power supply.
- Example: pressure gages

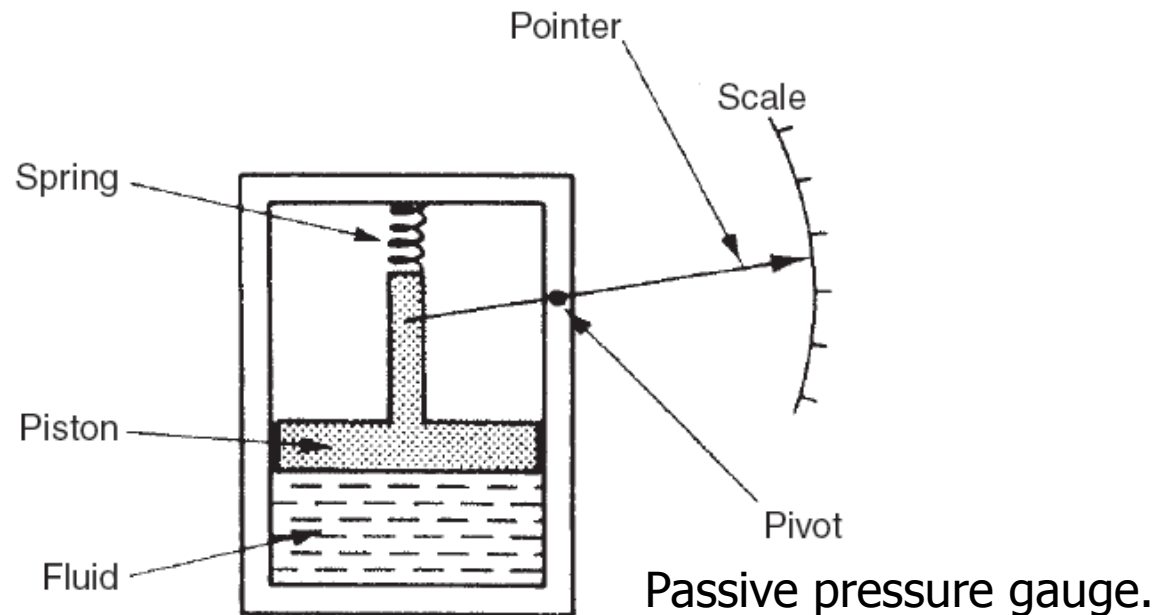

# Types of sensors: Active

- Require an external source of power that provides the majority of the output power of the signal
- In other words, external energy is added to the measurement environment as part of the measurement process.
- **Better resolution** control by the adjustment of the magnitude of the external energy input.

Active level sensor.

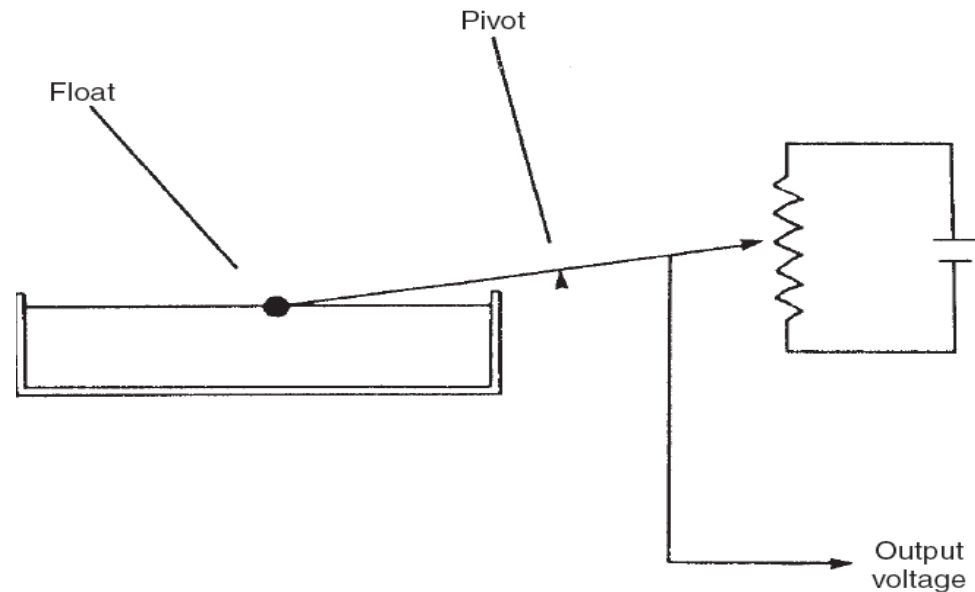

# Types of sensors: Analog/Digital

□ Analog sensors produce a signal which is continuous over time and proportional to the measurand.

□ **Example:** bulb thermometer.



□ Digital sensors provide a signal that is a direct digital representation of the measurand. Digital sensors are basically binary ("on" or "off") devices.

□ Example: A revolutionary counter.



# Outline

- What is a measurement system?
- Sensor and sensor types
- **Characteristics of sensor**
  - Static characteristics of sensors
  - Dynamic characteristics of sensors

# Characteristics of sensor

- **Static characteristics** of the sensor are its properties when all its dynamics settle down (steady state):
  - Sensitivity, offset & bias, span & dynamic range, saturation & dead zone, hysteresis & backlash, and nonlinearity.
- **Dynamic characteristics** of the sensor describe the sensor's transient properties and how it transiently responds to changes in measurands:
  - The reason for dynamic characteristics is the presence of energy-storing elements, masses, springs, inductances, capacitances.



# Characteristic of sensor

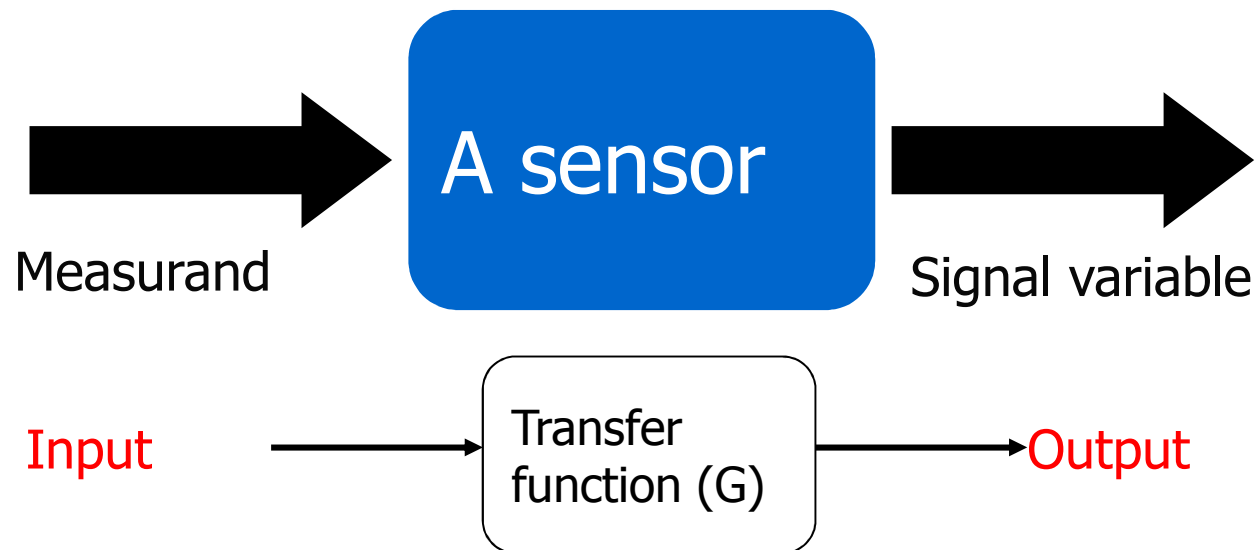

$$\text{Transfer function (G)} = G_{\text{static}} \times G_{\text{dynamic}}$$

(Transfer characteristics)

# Outline

- What is a measurement system?
- Sensor and sensor types
- Characteristics of sensor
  - Static characteristics of sensors
  - Dynamic characteristics of sensors

# Static Characteristics: Sensitivity

- The sensitivity of measurement system is a measure of the change in instrument output that occurs when the quantity being measured changes by a given amount.
- Sensitivity is also named **amplification factor** or **gain** (if greater than one) and **attenuation** (if less than one).
- Measured in the linear/nonlinear region of the curve.

$$\text{Sensitivity} = \frac{dS}{dx}$$

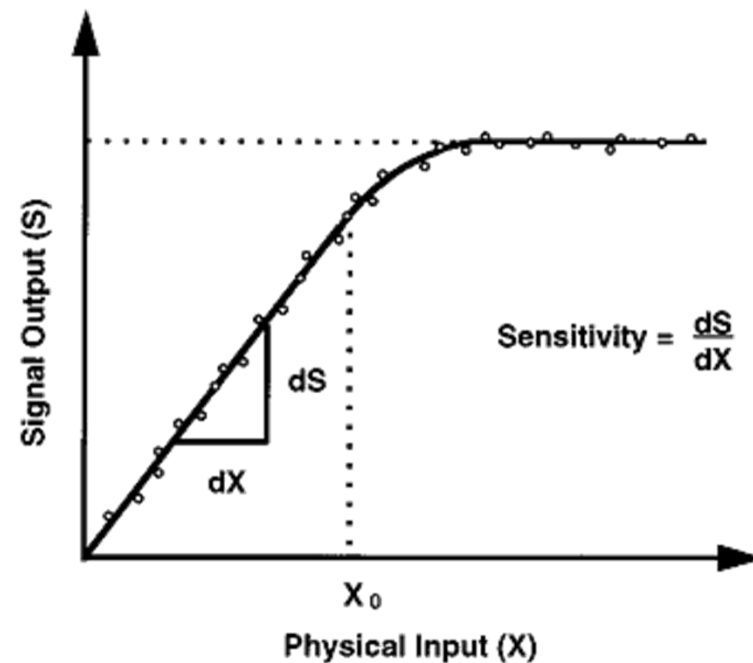

# Accuracy vs. Precision

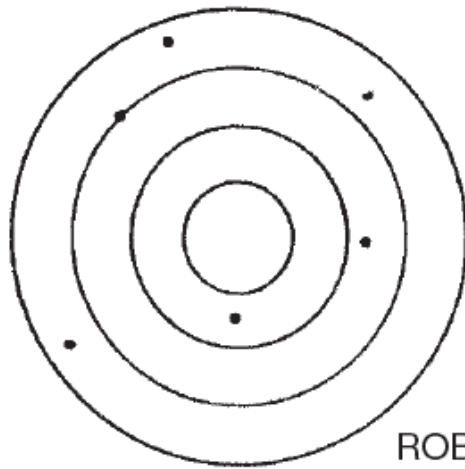

(a) Low precision,  
low accuracy

ROBOT 1

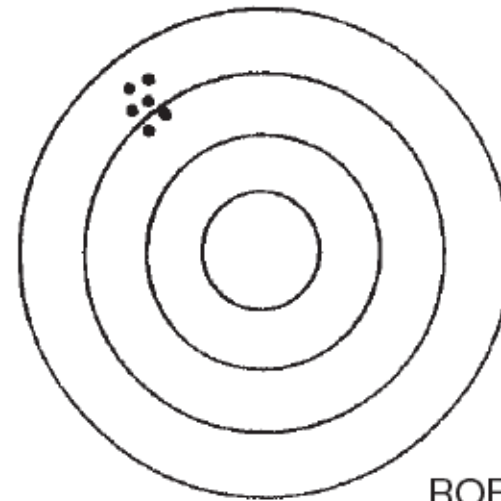

(b) High precision,  
low accuracy

ROBOT 2

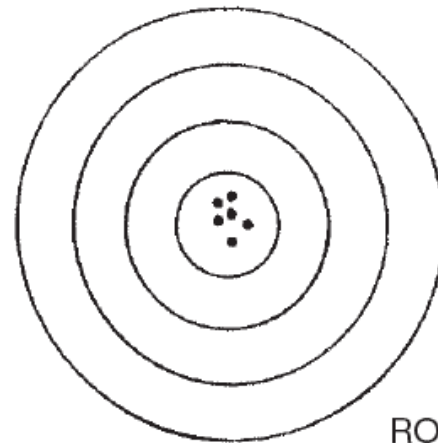

(c) High precision,  
high accuracy

ROBOT 3

# Static Characteristics: Definitions

## □ Accuracy:

- The *accuracy* of an instrument is a measure of how close the output reading of the instrument is correct.
- Usually indicated in terms of *inaccuracy*.

## □ Precision:

- *Precision* is a term that describes an instrument's degree of freedom from random errors.
- Can be improved by *recalibration*.

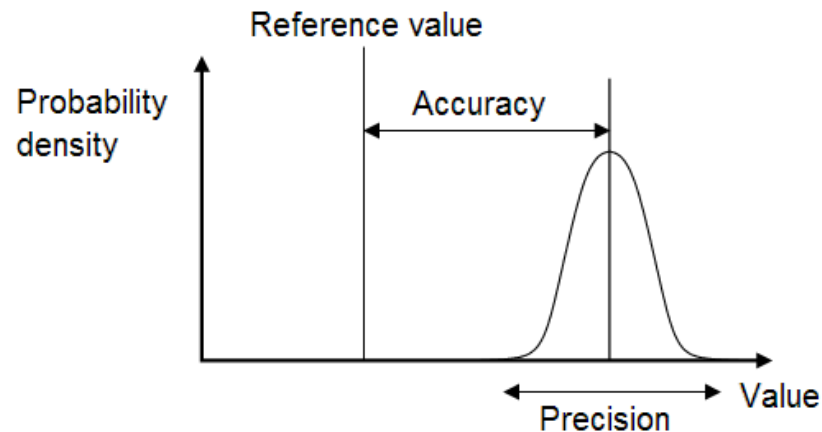

## Static Characteristics: Definitions (2)

### □ **Repeatability:**

- Describes the closeness of output readings when the same input, **from same item and using same instrument**, is applied repetitively over a *short period of time*, with the *same* measurement conditions.

### □ **Reproducibility:**

- Describes the closeness of output readings for the same input when there are *changes* in the method of measurement.

### □ **Resolution:**

- The minimum change in the input measurand that produces an observable change in the instrument output.

# Static Characteristics: Dynamic Range

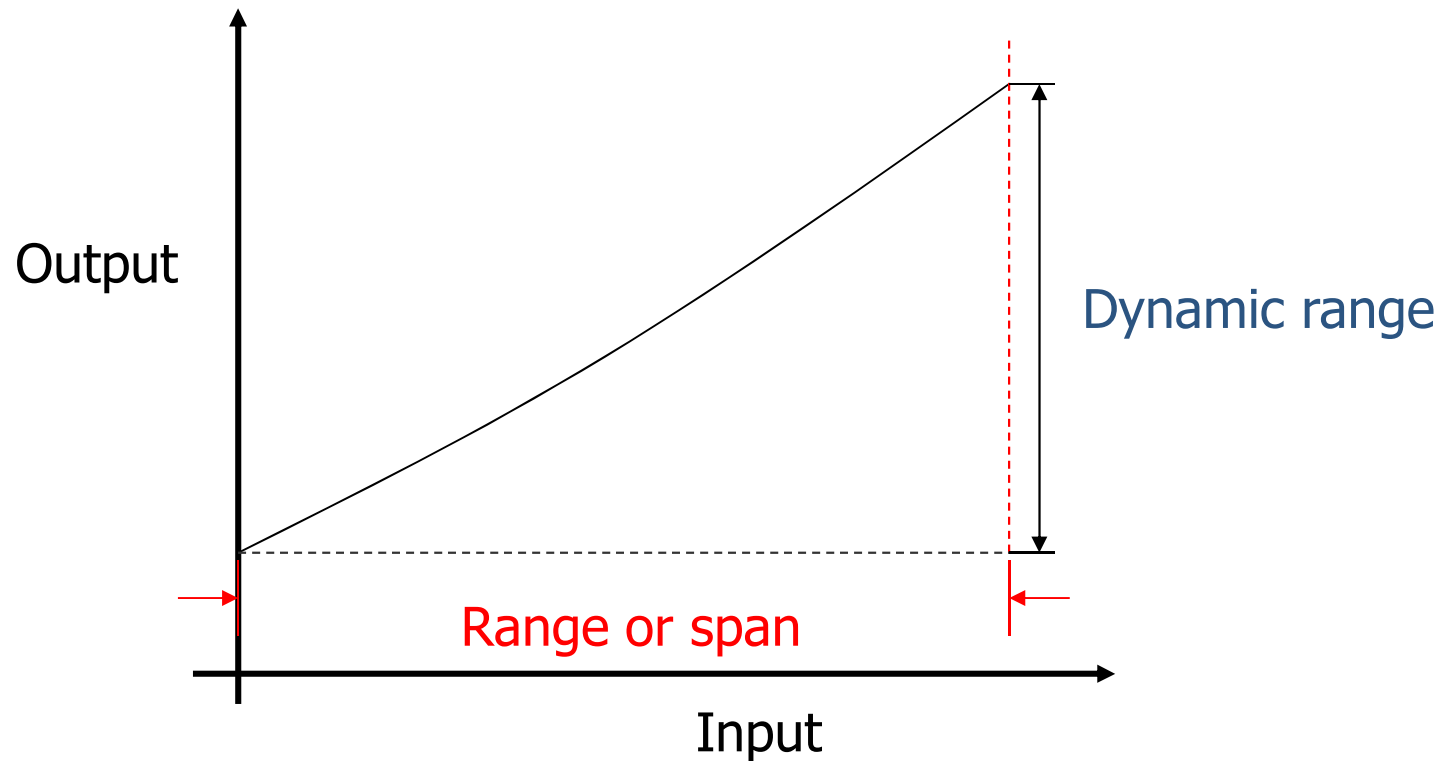

- Dynamic range: is the maximum and minimum value range within the input range (or input span).

# Static Characteristics: Offset & Bias

- Offset: is the output reading of the sensor without any input value.
- Bias: is a value which intentionally added to the sensor's output.

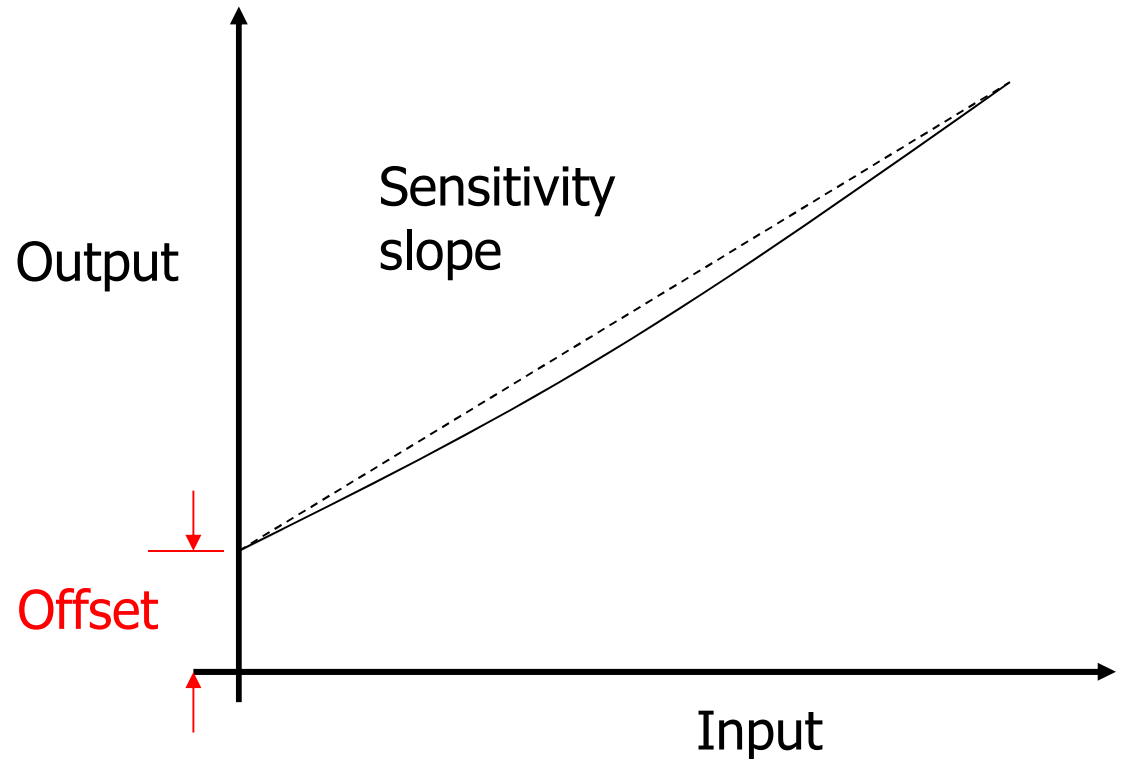



# Static Characteristics: Hysteresis and Backlash

- **Hysteresis:** when the value of output is affected by the direction of the change of the input.
- **Backlash:** when the output has sudden changes with the input

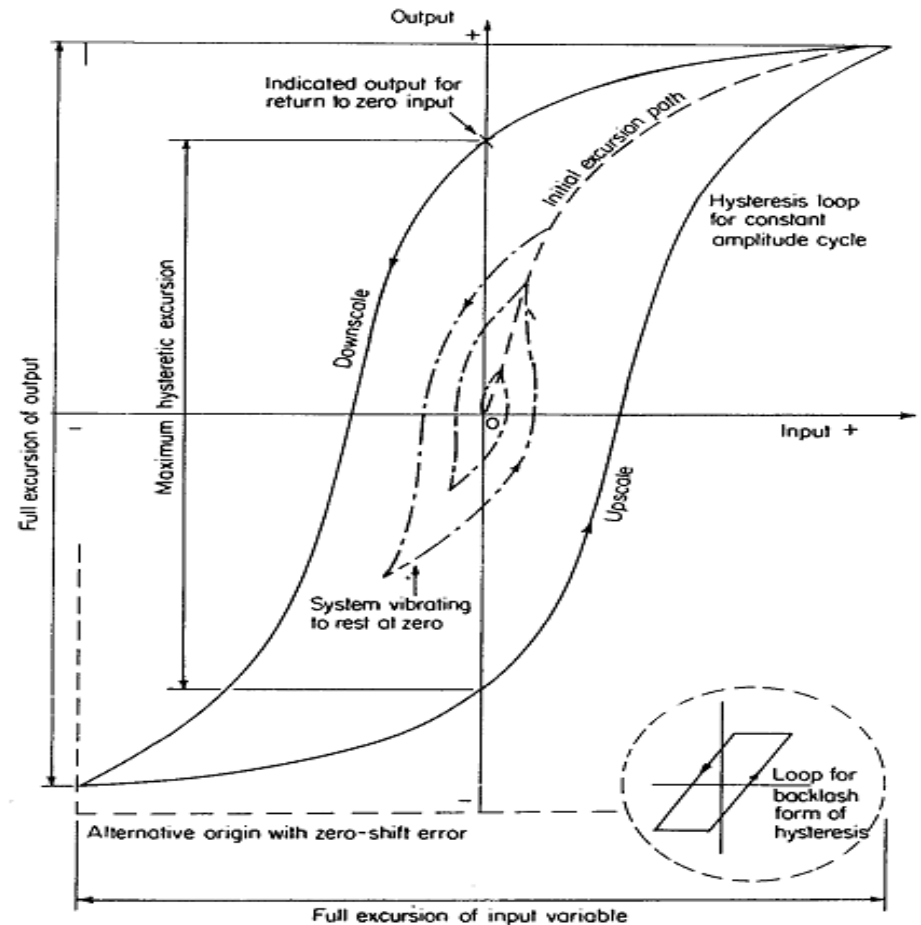

# Static Characteristics: Saturation and dead-zone

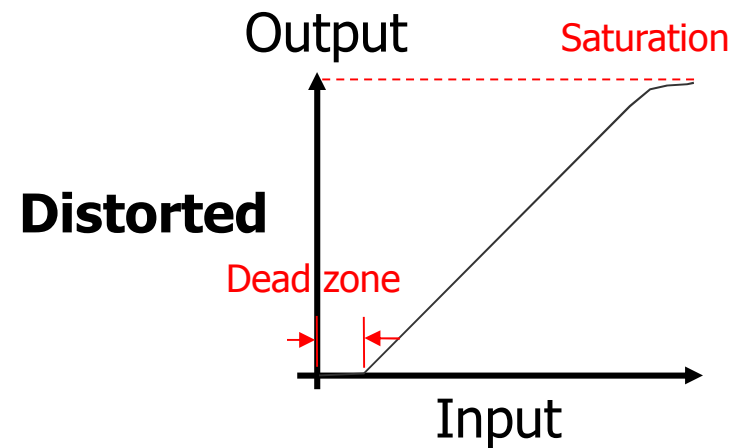
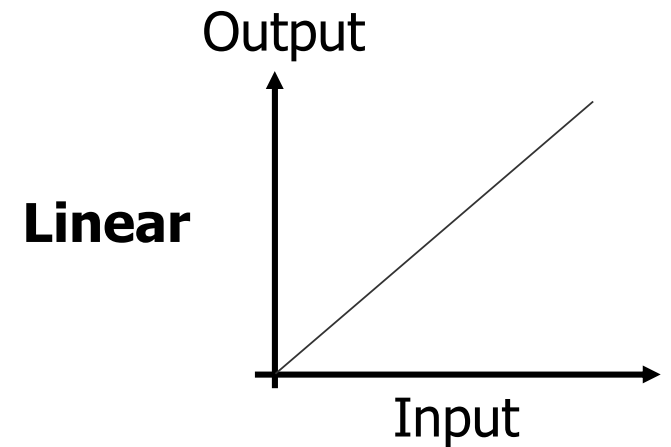
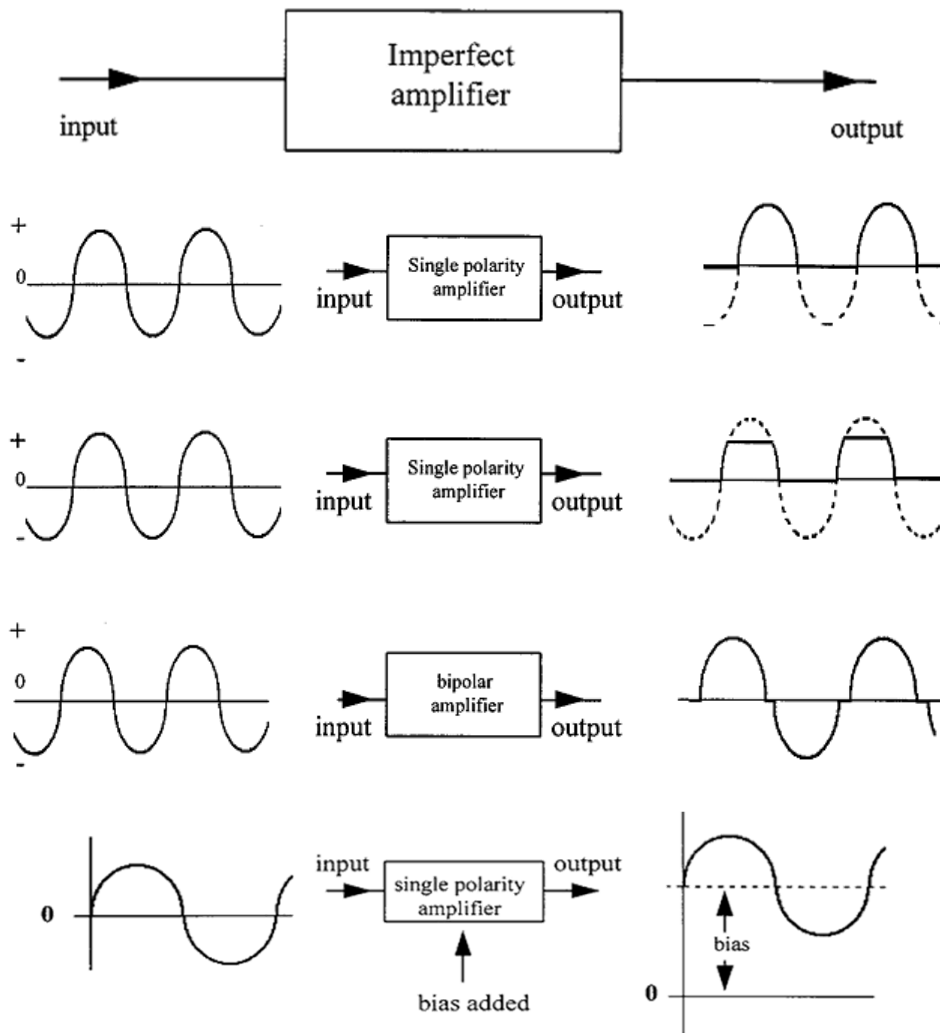

# Static Characteristics: Nonlinearity

- **Linearity:** it is the general term used to describe how close the actual response is compared with the straight-line approximation.

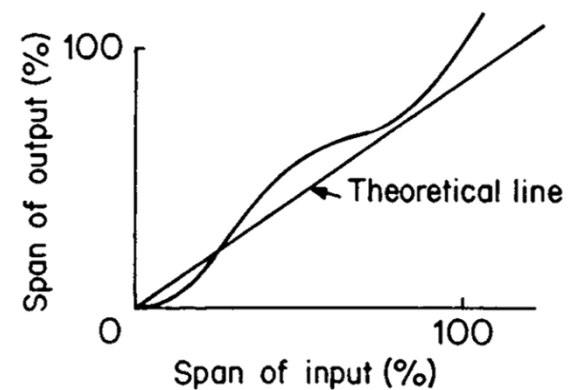
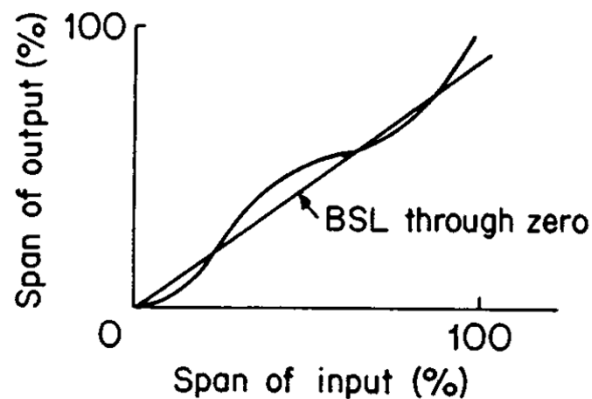
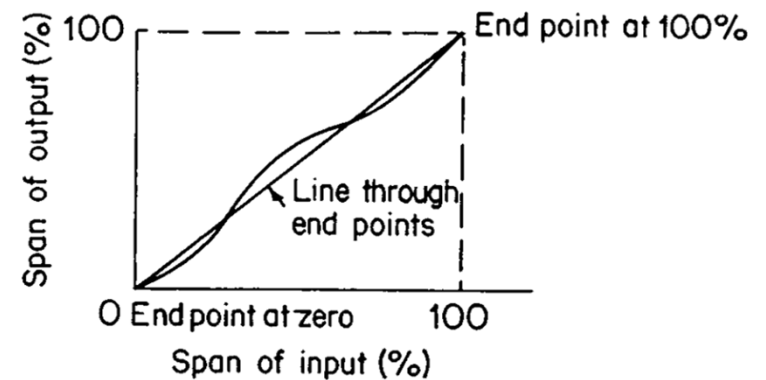
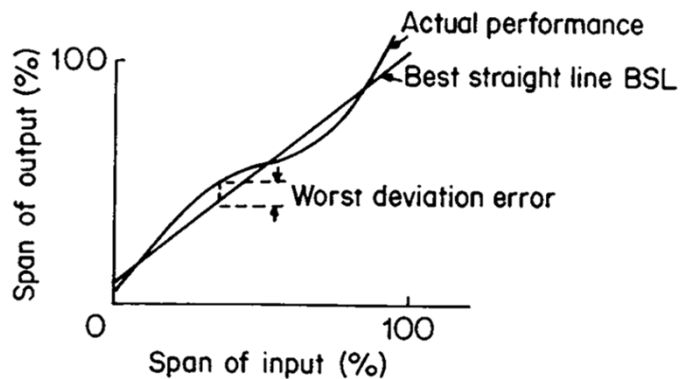

# Static Characteristics of Sensors: Nonlinearity

- For nonlinear systems, linearization can be done using Taylor's series:

Taylor series of a function  $f(x)$  around point ( $a$ ) is:

$$f(x) = f(a) + \frac{f'(a)}{1!} (x - a) + \frac{f''(a)}{2!} (x - a)^2 + \frac{f'''(a)}{3!} (x - a)^3 + \dots$$

# Outline

- What is a measurement system?
- Sensor and sensor types
- Characteristics of sensor
  - Static characteristics of sensors
  - Dynamic characteristics of sensors

# Dynamic Characteristics of Sensors:

- The dynamic characteristics of a measuring instrument describe its behavior between the time a measured quantity changes value and the time when its output attains a steady value in response.
- The behaviour of the sensor is described using a time-varying differential equation:

$$a_n \frac{d^n q_0}{dt^n} + a_{n-1} \frac{d^{n-1} q_0}{dt^{n-1}} + \dots + a_1 \frac{dq_0}{dt} + a_0 q_0 = b_0 q_i$$

- The solution depends on the order of the characteristic equation and the variation of  $q_i$  with time.
- Laplace transform is a very good tool for characteristic equation solution if it a linear differential equation.

# Dynamic Characteristics: Important inputs

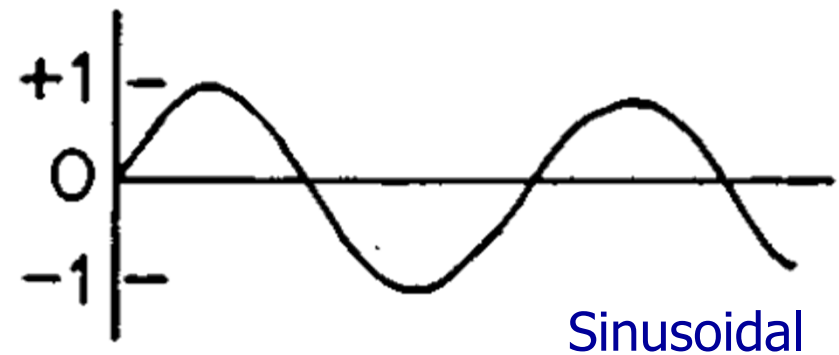
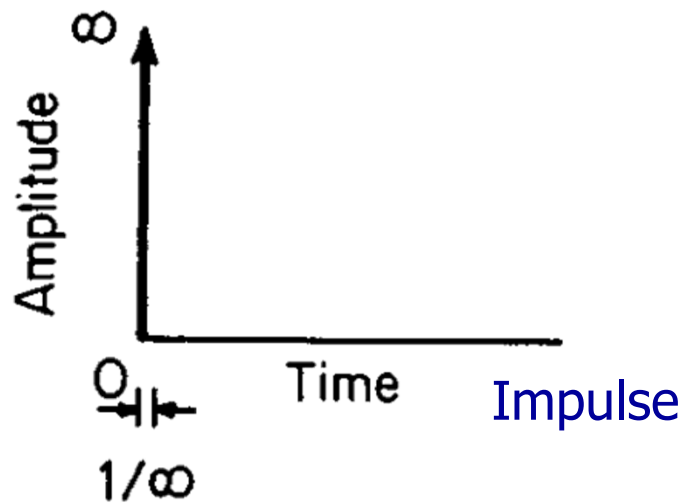
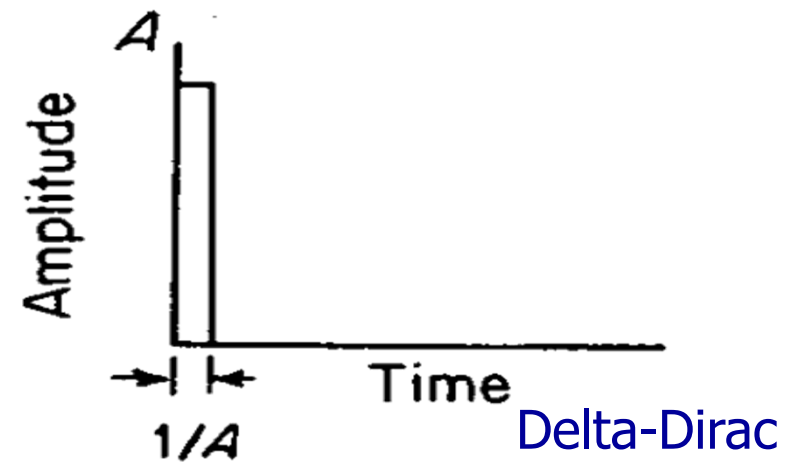
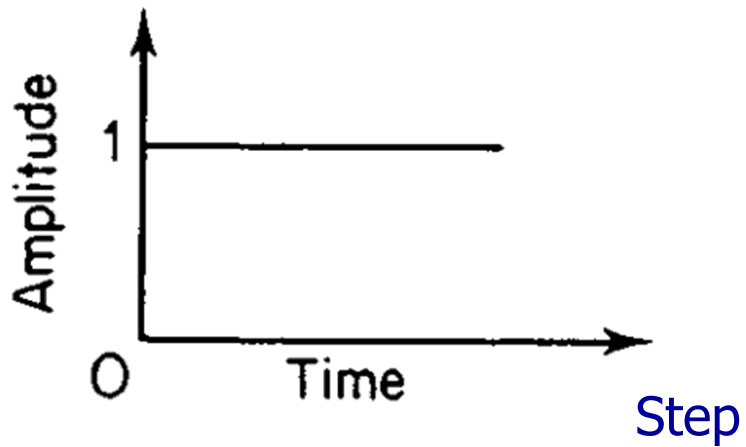

# Dynamic Characteristics: System response

| Order           | Characteristic Equation                                      | Transfer function (Y(s)/X(s))                         |
|-----------------|--|---|
| 0               | $a_0 y$  | $1/a_0$   |
| 1 <sup>st</sup> | $a_1 dy/dt + a_0 y$  | $1/(\tau s + 1)$                                      |
| 2 <sup>nd</sup> | $a_2 d^2y/dt^2 + a_1 dy/dt + a_0 y$                          | $1/(\tau_1 s + 1)(\tau_2 s + 1)$                      |
| n <sup>th</sup> | $a_n d^n y/dt^n + a_{n-1} dy^{n-1}/dt^{n-1} + \dots + a_0 y$ | $1/(\tau_1 s + 1)(\tau_2 s + 1) \dots (\tau_n s + 1)$ |



# Dynamic Characteristics: Zero-order system

Following a step change in the measured quantity at time  $t$ , the instrument output moves immediately to a new value at the same time instant  $t$

$$q_o = k q_i$$

**No energy storage elements.**

**Example:** A potentiometer measuring distance/motion

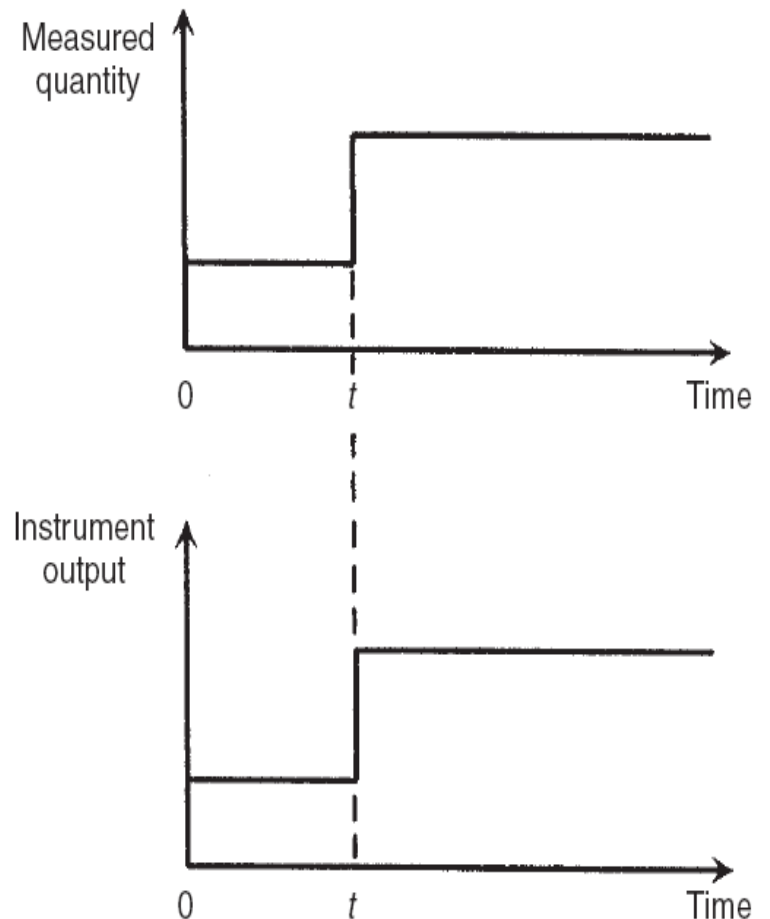

# Dynamic Characteristics: First-order system

$$a_1 \frac{dq_o}{dt} + a_o q_o = b_o q_i$$

$$q_o = \frac{k \cdot q_i}{1 + \tau \cdot D}$$

where:

- $k$  = static sensitivity =  $b_o/a_o$
- $\tau$  = time constant =  $a_1/a_o$

**Example:** Liquid glass thermometer

**One energy storage elements.**

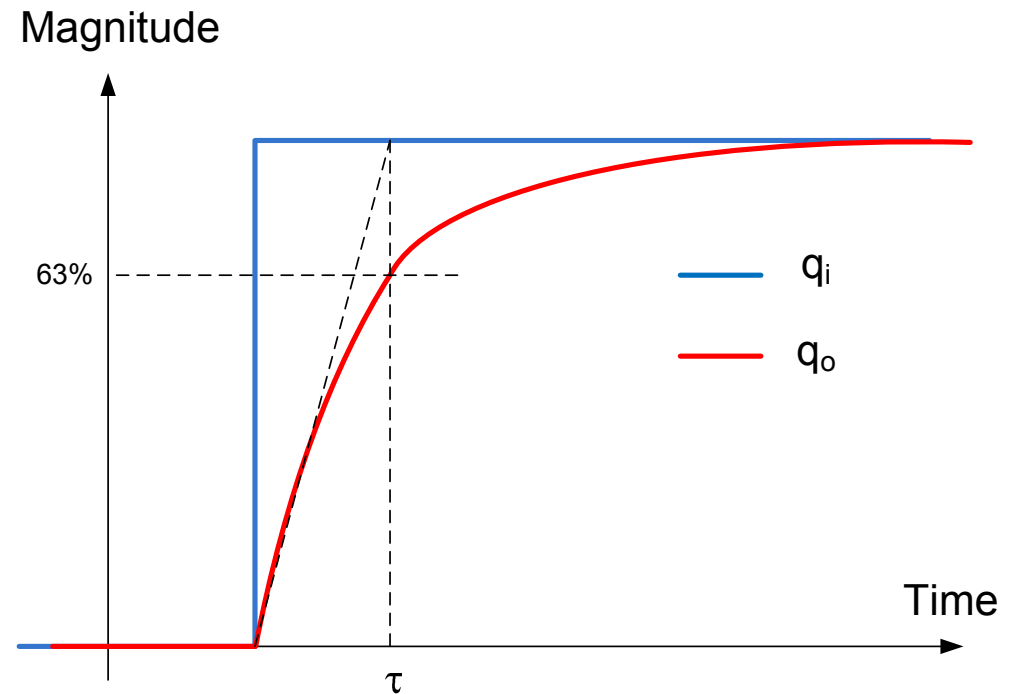

# Dynamic Characteristics: Second-order system

$$a_2 \frac{d^2 q_o}{dt^2} + a_1 \frac{dq_o}{dt} + a_o q_o = b_o q_i$$

$$q_o = \frac{k \cdot \omega_n^2 \cdot q_i}{D^2 + 2\zeta\omega_n D + \omega_n^2}$$

where:

- $k = b_o/a_o$
- $\omega_n = \sqrt{a_o/a_2}$
- $\zeta = a_1/[2 \sqrt{a_o a_2}]$
- **Example:** Inertial Sensors

**Two energy storage elements.**

